



# **Neo ProLink v3**

---

**IPOD TO FORD - PODFRD16V3**

**IPOD CONNECTION KIT  
INSTRUCTION MANUAL**

# NEO PROLINK

## **Ford**

With the Neo ProLink for Ford you can fully control on the iPod at ALL times. This adapter does not disable your iPod screen, buttons or click wheel. There are no special playlists that need to be setup, or specific naming of playlists. Your iPod will operate the same when connected in the car as it does when you listen to it with headphones. You'll also have track control from the radio buttons and steering wheel (if available) by using the track up, track down, fast forward and reverse buttons to change songs.

### FEATURES

Direct Connect - iPod plugs directly into car radio's CD Changer port.

Track Control – Change iPod songs from CD Changer buttons on car radio.

Direct Mode - Direct access and control of every playlist, song, artist and menu setting.

Charging and Power – iPod is powered and charging while in use, auto stops after 1 hour of non use.

### COMPATIBILITY

The Neo ProLink is compatible with all iPods with a DOCK connection located on the bottom of the iPod. This includes the following iPods;

*3rd Generation, 4<sup>th</sup> Generation, Mini, Photo, U2, HP, Nano and Video.*

The Neo ProLink connects your iPod directly to your stereo by connecting to the external CD changer port on the back of the radio. It will replace the external 6-disc CD changers. External CD changers plug into the actual radio and therefore it is not possible to have both an external 6-disc CD changer and the Neo ProLink connected at the same time. The CD player/changer which is an “in-dash” built into the radio will not be affected.

<u>Ford, Lincoln, Mercury</u>	<u>Yrs Compatible</u>	<u>Ford, Lincoln, Mercury</u>	<u>Yrs Compatible</u>
Aviator	2004-2005	LS	2004-2005
Continental, TownCar	2004-2005	Mariner	2005
Crown Victoria/G. Marquis	2003-2005	Mountaineer	2004-2005
Escape	2004-2005	Mustang	2004
Excursion	2000-2005	Navigator	2004-2006
Expedition	2004-2006	Sport Trac	2004-2005
Explorer / Freestar	2004-2005	Thunderbird	2004-2005

**Important: Radios MUST have external CD Changer capabilities. This kit IS compatible with radios that use a 16 and 24pin configuration. If you have any other connector on the radio, please contact NEO as your radio requires a different vehicle cable.**

**Not compatible with FORD vehicles equipped with Factory Navigation RSE/DVD systems or SAT radio – It must be disconnected.**

### IMPORTANT FORD RADIO NOTE:

Ford radios – 2004+ have many combinations of plugs and options. Compatibility for some radios can only be determined by removing the radio. If this kit is not compatible with your car, please contact Neo and they will get the kit that is. Be sure to note the connections you have on your radio (16pin, 20pin, 24pin etc), as well as the radio model number before calling. More times that not, we DO have an option for you.

**FORD did offer a 20pin radio with CDC capabilities. The radio is identical in look to the 24pin radio. If you happen to have the 20pin version. Please let us know as that kit is available.**

### IMPORTANT INSTALLATION INSTRUCTIONS PLEASE READ BEFORE INSTALLING

#### PACKAGE CONTENTS

Neo ProLink – Black Box  
Ford Cable (16 and 24 pin plug)  
iPod Cable

#### INSTALLATION STEPS

**Step 1:** Disconnect the negative battery terminal.

**Step 2:** Remove the radio.

**Step 3:** Unplug 24pin and 16pin connectors from radio if present.

**Step 4:** Plug the 24pin and 16pin connector into the radio.

**Step 5:** Reconnect the factory 24pin and 16pin harness (if present) into the “piggy back” of the Neo Ford cable.

**Step 6:** Connect the vehicle cable to the matching plug on the Neo box.

**Step 7:** Connect the ipod cable to the box. Do NOT connect the iPod.

**Step 8:** Reconnect the negative battery terminal.

**Step 9:** TEST the interface before reinstalling radio!

⇒ Turn car on, Turn iPod on. Connect iPod to iPod cable – your iPod should be charging.

⇒ Press the CD button 1-2x on the radio, radio should respond and switch to the iPod.

**Step 10:** Reinstall the radio back into the dash of the vehicle.

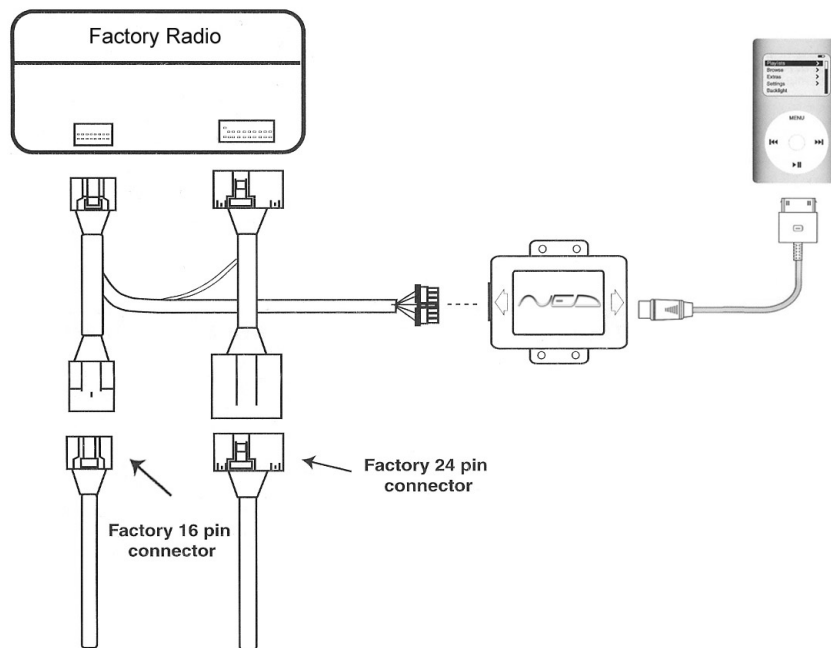

## USER'S GUIDE

### CONNECTING AND PLAYING THE IPOD

Turn your radio on before connecting the iPod. When the iPod is connected to the adapter, press the CD button 1-2X and you will see the radio enter into external CD Changer mode – “iPod Mode”.

### WARNING!!

Use only the iPod connector cable which comes with the Neo adapter. Other cable's may look similar, but can cause damage to iPods and to the Neo adapter.

### CONNECTING AND PLAYING THE IPOD

Turn your radio on before connecting the iPod for the first time. When the iPod is connected to the adapter. Push the CD button to access the iPod (if you have a single CD player, press the button twice).

### WARNING!!

Use only the iPod connector cable which comes with the Neo ProLink . Other cable's may look similar, but can cause damage to iPods and to the Neo ProLink adapter.

### TRACK CONTROL

Press the forward track button ▶ to advance to the next track in the folder you are in (playlist, album, artist, etc).

Press the previous track button ◀ to go to the beginning of the track.

Press the previous track button twice ◀ (x2) to go to the previous track (some radio's only need to be pressed once).

Press the fast forward button ▶▶ to fast forward and rewind button to ◀◀ (some radio track buttons have dual features and would require you to press and hold the ◀ or ▶ buttons).

There may be slight delay times when changing tracks depending on the radio software loaded from the factory and how quickly it will communicate with the adapter and the iPod. If the ◀ or ▶ buttons are pressed very quickly and the iPod has not been allowed enough time to change tracks, the track number display on the radio may not load correctly. You will also hear short bits of audio if these buttons are pressed too quickly. Remember that you have full access to your iPod buttons, so if you need to quickly change through track or are searching for a particular artist/song, you can also use the iPod itself.

If your radio only has the ability to display a two digit readout, when you reach song 100 the radio will either peak at 99 or restart back at track 1. If it peaks at 99, you will still be able to continue advancing tracks, but the radio will not be able to display the correct track number. You are NOT limited to only 99 songs; you can have as many songs in a playlist as you choose (9,999). If your radio restarts at 01 then the track number 100 displays as 01, track 101 as 02, and track 102 as 03, etc.

Many older CD playing radios (especially ones without MP3 capabilities) don't have three character readouts, because the average CD only went to 20+ songs.

### SWITCHING BETWEEN SOURCES (AM/FM, CD, Cassette)

When a source other than the iPod is selected on the radio, the iPod will pause.

## **NOTICES, WARNINGS, AND WARRANTY**

### **One Year Limited Warranty**

The quality controls used in the manufacture of this product ensure your satisfaction. This warranty applies only to the original purchaser of this product from an authorized dealer. This warranty covers any supplied or manufactured parts of this product that, upon inspection by NEO CAR AUDIO authorized personnel, is found to have failed in normal use due to defects in material or workmanship. This warranty does not apply to installation expenses. Operating this unit under conditions other than those recommended or voltages other than the voltage indicated on the unit, or attempting to service or modify the unit, will render this WARRANTY VOID. Unless otherwise proscribed by law, NEO CAR AUDIO shall not be liable for any personal injury, property damage or any incidental or consequential damages of any kind (including water damage) resulting from malfunctions, defects, misuse, improper installation or alteration of this product.

All parts of this NEO CAR AUDIO product are guaranteed for a period of 1 year as follows:

Within the first 12 months from date of purchase, subject to the conditions above, NEO CAR AUDIO will repair or replace the product if it is defective in material or workmanship providing it is returned to NEO CAR AUDIO, with PROOF OF PURCHASE from an authorized dealer. If you have a problem with this product, please call or write to our Customer Service Dept.

All warranty repair must have a RMA number from our service department. Contact Neo Car Audio for further warranty repair info.

### **Warning:**

1. This equipment may be reset by unintentional electrostatic discharge during operation. Exposure to direct sunlight or extreme heat may cause damage or malfunction.
2. Do not disassemble or alter the cable and interface box.
3. Make the connections correctly
4. Do not cut away the wire sheath and use the power for other equipments.
5. Do not install in locations which might hinder vehicle operation or create hazards for vehicle occupants.
6. Have the wiring and installation done by professionals.
7. Arrange wiring so it is not crimped or pinched.
8. Do not use this product for purposes other than stated for the vehicle.

### **Caution:**

1. The ACC Switch Output Connector has 10mA drive capability only. You must use a relay if higher ACC power output is required.
2. Use of headphones while operating an automobile or moving vehicle is not recommended and is unlawful in some countries and areas.
3. Be careful and attentive on the road. Stop operation of the Neo ProLink if you find it disruptive or distracting while driving. The driver of a motor vehicle should not operate the Neo ProLink while driving.

### **FCC Class B Radio Frequency Interference Statement**

This equipment has been tested and found to comply with the limits for a Class B digital device, pursuant to Part 15 of FCC rules. These limits are designed to provide reasonable protection against harmful interference in a residential installation. This equipment generates, uses, and can radiate radio frequency energy and, if not installed and used in accordance with the instructions, may cause harmful interference to radio communications. However, there is no guarantee that interference will not occur in a particular installation. If this equipment does cause harmful interference to radio or television reception, which can be determined by turning the equipment off and on, the user is encouraged to try to correct the interference by one or more of the following measures:

1. Reorient or relocate the receiving antenna.
2. Increase the separation between the equipment and receiver.
3. Connect the equipment into an outlet on a circuit different from that to which the receiver is connected.
4. Consult the dealer or an experienced radio/television technician for help.

Notice 1: The changes or modifications not expressly approved by the party responsible for compliance could void the user authority to operate the equipment.

Notice 2: Shielded interface cables, if any, must be used in order to comply with the emission limits.

### **Copyrights, warnings, and other information**

The illustrations, technical information, data and descriptions contained in this publication are subject to change without notice. This publication, together with all information contained in it, and all intellectual property rights on this publication remain the property of NEO CAR AUDIO. The user may not pass this publication on to third parties. No liability will be accepted for any inaccuracies or omissions in this publication, although due care has been taken to make it as complete and accurate as possible

iPod, 3rd Generation, 4th Generation, Mini, Photo, U2, HP, Nano and Video are registered trade marks of Apple Computers, Inc.

Ford is a registered trade mark of Ford Motor Company.

Product design and specifications are subject to change without notice, this includes the iPod CABLE, adapter BOX, etc. Neo does not guarantee the accuracy of the retail product picture - changes are made without notice to our dealers. Neo uses several cases for its adapters, yet ONE common "retail" picture may be used.

## **Looking for an iPod Car Connection Kit for another vehicle radio?**

Visit [www.neocaraudio.com](http://www.neocaraudio.com) for more info. 619-704-0690