



# Neo interface for iPod

for selected Audi/Volkswagen vehicles

Installation Guide/User Manual  
for model number Audi/VW-CDC and Audi/VW-SAT integration kits



Copyrights and Trademarks

Copyright 2008 Neo Car Audio Inc.





The Neo Car Audio Inc. logo is a trademark of Neo Car Audio Inc.

iPod is a trademark of Apple, Inc.

All rights reserved.

Printed in the U.S.A

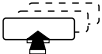
## Table of contents

Copyrights and trademarks	3	iPod audio source	28
Icon legends	3	Controls in SAT emulation	28
Warranty and safety	4	Browsing function in SAT emulation	29
Product registration	5	Scrolling feature	30
Supported iPod models	6	Auxiliary audio source	31
iPod hierarchy	7	Troubleshooting	33
Charging	7	Disclaimer	35
Audi/VW-CDC integration kit	8-19	<b>Icon legends</b>	
Integration kit contents	9	 Turn jog dial	
DIP switches	10	 Turn jog dial repeatedly	
DIP switch settings	11	 Press button	
Installation	12	 Press button repeatedly	
iPod audio source	18	 Scroll	
Controls in CDC emulation	18		
Browsing function in CDC emulation	19		
Audi/VW-SAT integration kit	20-29		
Integration kit contents	21		
DIP switches	22		
DIP switch settings	23		
Installation	24		

## Warning and safety!

Please read these instructions carefully before proceeding. Failure to follow instructions may result in improper operation or injury. Neither Neo Car Audio Inc. nor Apple Inc., its regional offices, distributors or resellers take any responsibility for any damage or injury as a result of using the integration kit.

- Do not open, disassemble or alter the interface in any way.
- Do not insert anything into the casing.
- Do not cut or try to alter cables in any way and always use the correct connections.
- Only operate unit when stationary or ask passengers to operate it for you.
- Do not allow the Apple iPod to distract you from driving.
- Exercise good judgement and keep your eyes on the road at all times.
- Do not expose unit to extreme temperatures, humidity or shock.
- Keep the unit and iPod away from fluids.
- Keep away from children! - Interface components may contain small parts, can be broken or disassembled and components may become loose from vibration and heat. Small components and packaging materials may be a choking hazard when handled by children.

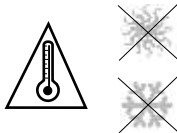



## Congratulations on your purchase

Thank you for purchasing the Neo integration kit for iPod. Please review our user manual and installation guide before operating the unit. This interface was designed and manufactured to seamlessly integrate with your vehicle's factory entertainment system.

## Product registration

In order to validate your warranty period and to receive telephone or online support, you **MUST** register your product.

To register your Neo product, please complete the following steps:

1. Visit <http://www.neocaraudio.com>
2. Complete the product registration form.
3. Submit the form.
4. Save the registration/support/warranty sheet in a safe place for future reference.

If you are unable to complete the registration via internet, please call Neo Car Audio Inc. at 619-704-0699.

## Supported iPod models and firmware version requirements

FW:3.1.1



iPod  
4th generation  
20GB 40GB

FW:1.2.1



iPod  
4th generation color display  
20GB 30GB 40GB 60GB

FW:1.0.3



iPod classic  
80GB 160GB

FW:1.2.1



iPod  
5th generation (video)  
30GB 60GB 80GB

FW:1.4.1



iPod mini  
4GB 6GB

FW:1.0.3



iPod nano  
3th generation (video)  
4GB 8GB

FW:1.3.1



iPod nano  
1st generation  
1GB 2GB 4GB

FW:1.1.3



iPod nano  
2nd generation (aluminum)  
2GB 4GB 8GB

FW:1.1.1



iPod touch  
8GB 16GB 32GB

For the latest firmware versions and models not listed, please contact your authorized dealer or Neo Car Audio Inc.

## iPod hierarchy

By default, the interface creates a Playlist having a name that is the same as the name of the iPod. This Playlist is the very first on the list of Playlists shown while browsing in Playlist mode. This Playlist contains all the songs on the iPod. Once a Playlist is active an Artist may be selected within that Playlist using the Artist Mode. Albums by the selected Artist and within the selected Playlist may be selected in Album Mode. "ALL ARTIST" and "ALL ALBUM" designate all available content in those categories.

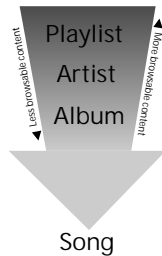

## Charging

The interface automatically charges the battery of the iPod when connected and the key is in the ACC/ON position.

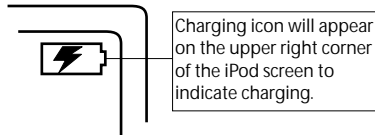



# Audi/VW-CDC integration kit

---

## Integration kit contents

- 1 Vehicle specific interface unit
- 1 iPod docking cable
- Vehicle specific harnesses (R,R1,R2)\*
- 1 User manual

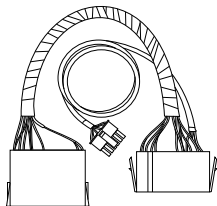
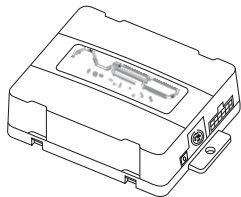
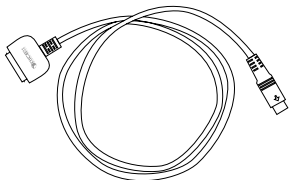

Audi-R harness



VW-R1 harness



VW-R2 harness

\* Note that your kit may contain one or more harnesses.

## Dip switches

The configuration switches located on the Neo module are used to set the operation of the interface by the installer. Incorrect dip switch settings may cause the Neo interface not to work properly or not to operate at all. Disconnect the vehicle harness from module and cycle ignition off for 50 seconds after changing the switches!

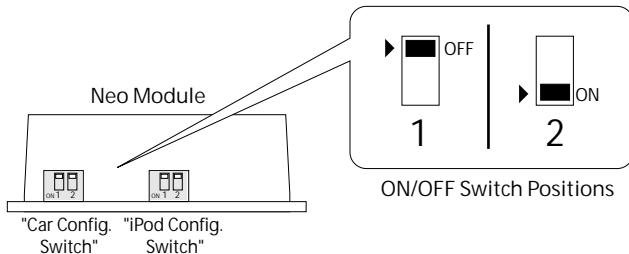

## Dip switch settings

Car configuration switches	
Settings	
CD changer (CDC)	
Dip switch 1	Dip switch 2
OFF	OFF
Switches should remain in the default OFF position.	

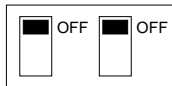

Default

iPod configuration switches			
Settings			
"Locked"		"iPod"	
Dip switch 1	Dip switch 2	Dip switch 1	Dip switch 2
OFF	OFF	ON	ON
It is best selected when <u>advanced controls on the radio are used</u> . After the initialization the iPod will be locked for an increased interface functionality.		It is best selected when <u>text display is not supported by the radio and user wishes to retain iPod control</u> . Track numbers and times are not synchronized between the iPod and radio. Because there is less data transfer between the iPod and radio, this mode has the fastest response time. Content is selected on the iPod.	

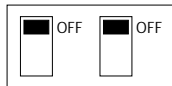

Default



## Installation

Installation should only be performed by a qualified professional. Beware of sharp edges to avoid injury and exercise caution when removing trims as they may break. The module should be placed at an accessible location to allow AUX cable to be connected, such as in the glove box, the center console or under the front seat.

- 1 Pull vehicle into service bay and access radio/center console.
- 2 Disconnect both battery terminals. These cables must be disconnected during installation to ensure proper initialization of the module when it is connected. Make sure that radio code is available before starting installation.
- 3 Before pulling out the radio, remove surrounding trims and screws. Most trims can be removed by carefully pulling on the piece or using trim removal tools. Trim is usually held in place by snap-in clips.
- 4 To remove the radio you need to use the appropriate radio removal tool. Consult your dealership if additional information is needed on removing the radio.

5a - Audi radios with R connectors - You can access the CD changer connector located on the back of the radio. Unplug the factory connection if present and plug the Audi-R BUS connector into the receptacle. The connector should securely lock. Ground wire **MUST** be connected to a stable grounding point.

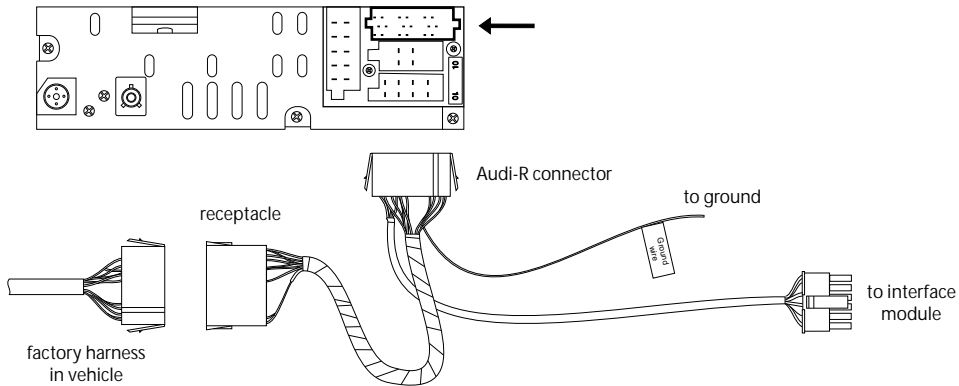

- 5b - VW radios with R1 connectors -You can access the CD changer connector located on the back of the radio. Unplug the factory connection if present and plug the VW-R1 BUS connector into the receptacle. The connector should securely lock. Ground wire **MUST** be connected to a stable grounding point.

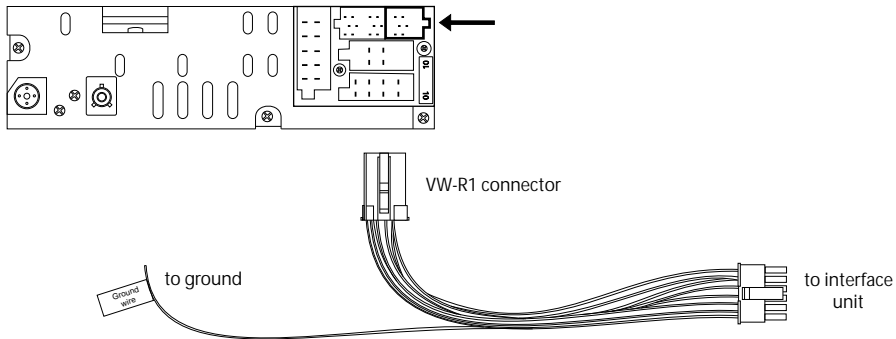

5c - VW radios with R2 connectors - You can access the CD changer connector located on the back of the radio. Unplug the factory connection if present and plug the VW-R2 BUS connector into the receptacle. The connector should securely lock. Ground wire **MUST** be connected to a stable grounding point.

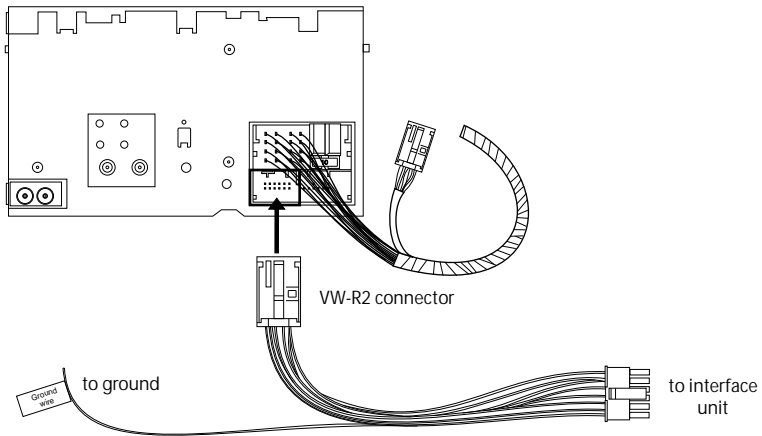

5c - Cable modification - If vehicle is equipped with factory Satellite radio and desired to be retained, a harness modification is required.

- 1 Disconnect main radio harness and locate SAT connector. Remove it from main harness by pressing on the release tab of the SAT connector.

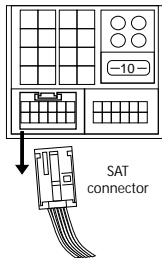

- 2 Slide out the inner part of the SAT connector from plastic housing.

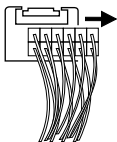

- 3 Disassemble the VW-R2 connector the same way as the factory SAT connector.

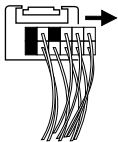

- 4 Remove the SAT wires from the factory connector by releasing the pins with a small screw driver or ball-point pen.

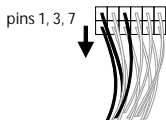

- 5 Relocate wires to VW-R2 connector keeping the same order and location.

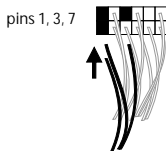

- 6 Put plastic connector covers back on. Insert VW-R2 connector to factory VW main harness.

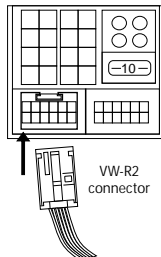

- 7 Connect ground wire to chassis of radio.

- 6 Connect the vehicle specific connector and the iPod docking cable to the Neo module. Apply cable ties to secure the cables.

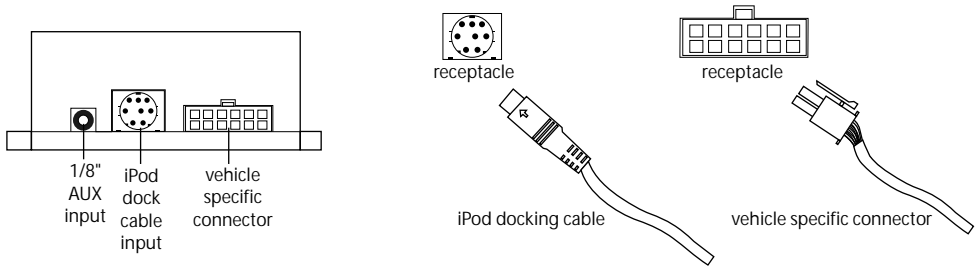

- 7 Verify that all connections have been properly made.

- 8 Reconnect the car's battery. Test the unit before seating the cables and reinstalling the panels/trim.



## Browsing function - in CDC emulation

After connecting the iPod and selecting the CD changer source, use the desired mode by selecting DISC 1-4. To change Track press the Track button or turn the Tune dial. Text display is not supported, however recent iPod firmware upgrades show the Title/Artist information of the currently played song. Alternately, you may select iPod mode (p.11).

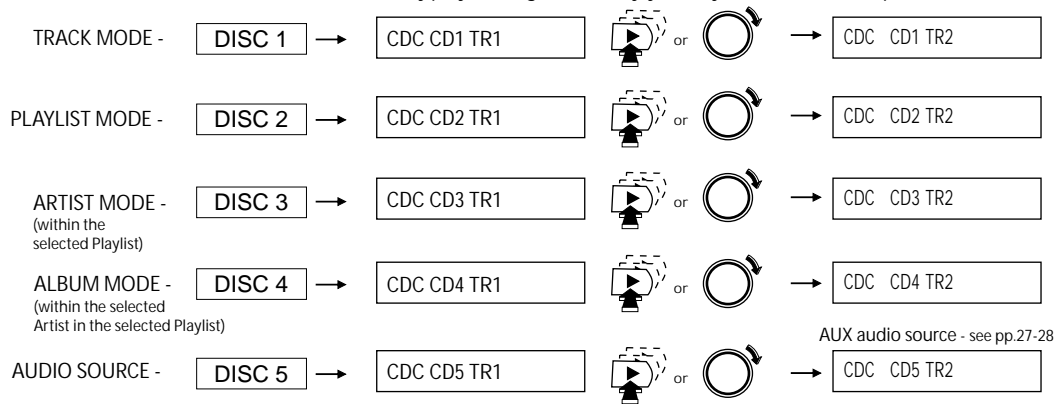

AUX audio source - see pp.27-28

## Audi/VW-SAT integration kit

---

## Integration kit contents

- 1 Vehicle specific interface unit
- 1 iPod docking cable
- Vehicle specific harnesses (Audi/VW-CAN)\*
- 1 User manual

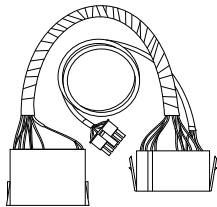
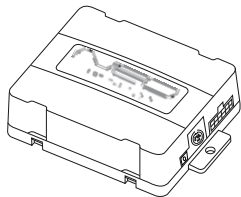
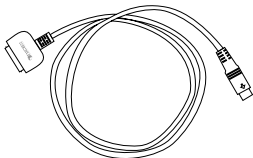

Audi/VW-CAN harness (type 1)

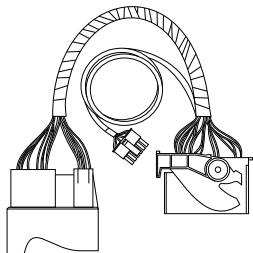

Audi/VW-CAN harness (type 2)

\* Note that your kit may contain one or more harnesses, in some cases they may look different from the ones illustrated above.

## Dip switches

The configuration switches located on the Neo module are used to set the operation of the interface by the installer. Incorrect dip switch settings may cause the Neo interface not to work properly or not to operate at all. Disconnect the vehicle harness from module and cycle ignition off for 50 seconds after changing the switches!

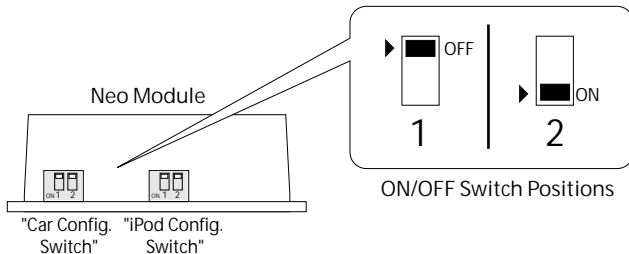

## Dip switch settings

Car configuration switches	
Settings	
Satellite (SAT)	
Dip switch 1	Dip switch 2
OFF	OFF
<p>Recommended for Satellite (XM/Sirius) capable radios. This type of emulation provides <u>full text display</u> on the radio. If Satellite (XM/Sirius) is equipped it must be disconnected to operate integration in this emulation mode. XM/Sirius receiver is usually located in the trunk or under the passenger seat.</p>	

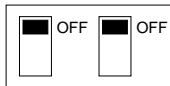

Default

iPod configuration switches			
Settings			
"Locked"		"iPod"	
Dip switch 1	Dip switch 2	Dip switch 1	Dip switch 2
OFF	OFF	ON	ON
<p>It is best selected when <u>text display is supported</u> by the radio. After the initialization the iPod will be locked for an increased interface functionality.</p>		<p>It is best selected when <u>text display is NOT supported</u> by the radio. Track numbers and times are not synchronized between the iPod and radio. Because there is less data transfer between the iPod and radio, this mode has the fastest response time. Content is selected on the iPod.</p>	

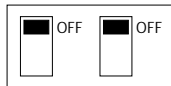

Default



## Installation

Installation should only be performed by a qualified professional. Beware of sharp edges to avoid injury and exercise caution when removing trims as they may break. The module should be placed at an accessible location to allow AUX cable to be connected, such as in the glove box, the center console or under the front seat.

- 1 Pull vehicle into service bay and access radio/center console.
- 2 Disconnect both battery terminals. These cables must be disconnected during installation to ensure proper initialization of the module when it is connected. Make sure that radio code is available before starting installation.
- 3 Before pulling out the radio remove surrounding trims and screws. Most trims can be removed by carefully pulling on the piece or using trim removal tools. Trim is usually held in place by snap-in clips.
- 4 To remove the radio you need to use the appropriate radio removal tool. Consult your dealership if additional information is needed on removing the radio.

5a - Audi/VW radios with "Y-harness" type CAN1 connection - You can access the SAT connector located on the back of the radio. Unplug the factory connection if present and plug the Audi/VW CAN connector in. Connect the factory plug to the cable receptacle if it was removed from the radio. The connector should securely lock. The factory SAT tuner must be disconnected at the tuner which is usually located in the trunk or under the passenger seat. For detailed information refer to the service manual of your vehicle.

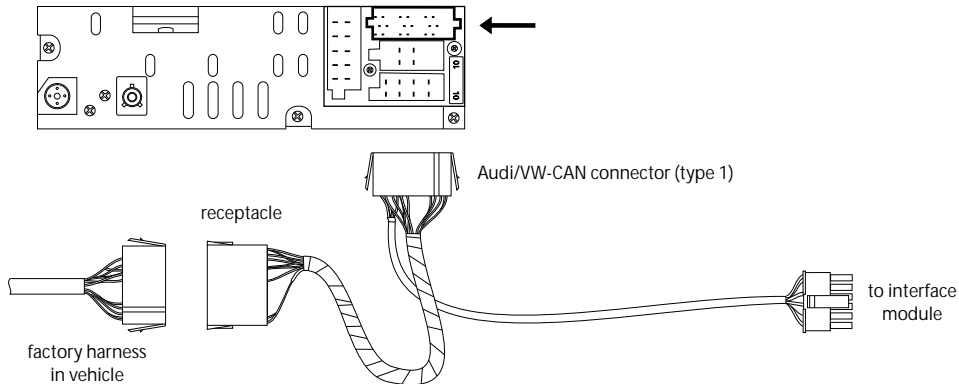

5b - Audi/VW radios with "Y-harness" type CAN2 connection - You can access the SAT connector located on the back of the radio. Unplug the factory connection if present and plug the Audi/VW CAN connector in. Connect the factory plug to the cable receptacle if it was removed from the radio. The connector should securely lock. The factory SAT tuner must be disconnected at the tuner which is usually located in the trunk or under the passenger seat.

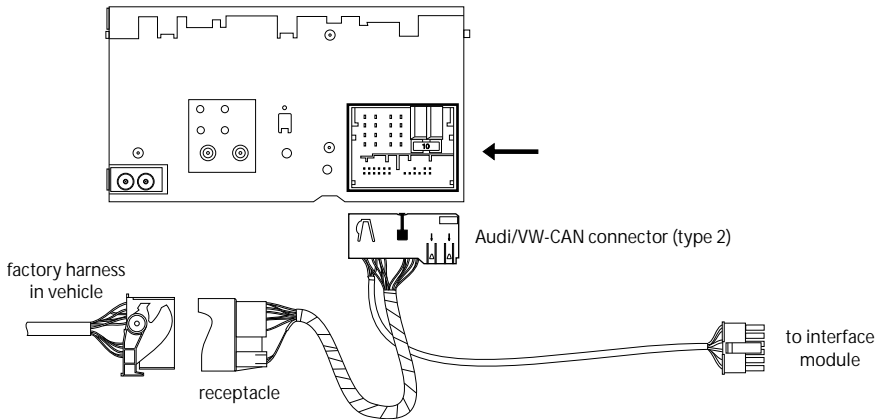

- 6 Connect the vehicle specific connector and the iPod docking cable to the Neo module. Apply cable ties to secure the cables.

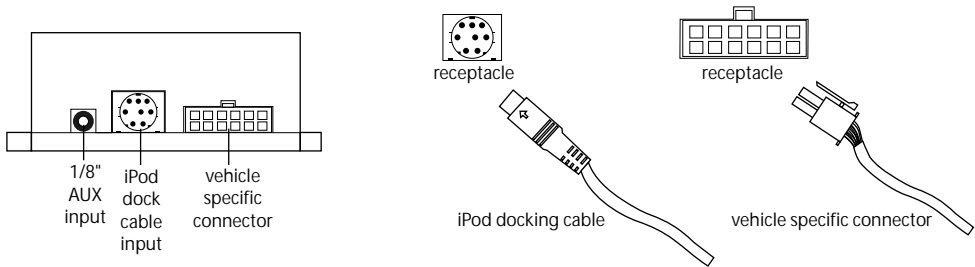

- 7 Verify that all connections have been properly made.

- 8 Reconnect the car's battery. Test the unit before seating the cables and reinstalling the panels/trim.

## iPod audio source

### Controls in SAT emulation

Press the SAT button to access the interface and its features. When the iPod audio source is active (Mode 5, Channel 1), use the Track button or the Tune dial to select next/previous Song.

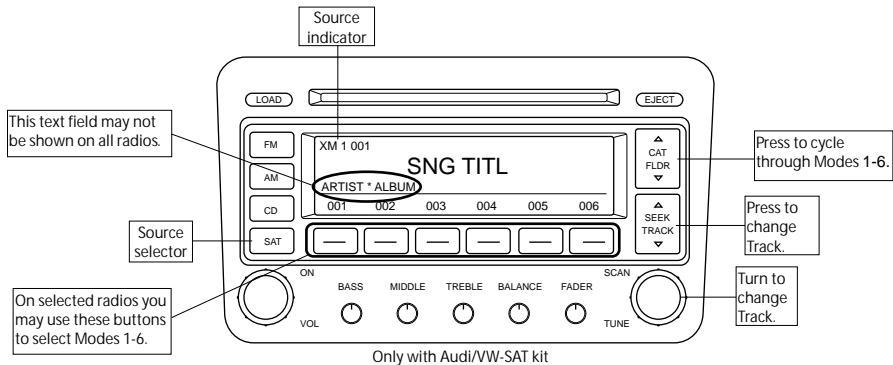

## Silverline browsing function - in SAT emulation

The Silverline integration kit features content browsing. After connecting the iPod, select the desired browsing mode by pressing the appropriate CAT/FLDR button. Press the Seek/Track button or turn the Tune dial repeatedly to browse contents; 1 second after releasing the button, your selection is executed.

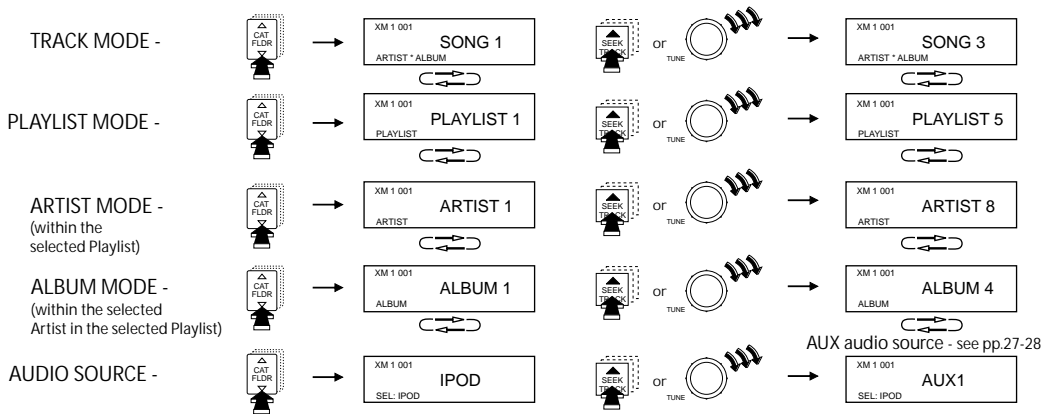

AUX audio source - see pp.27-28

## Scrolling feature - in SAT emulation, Mode 6 (Only with Audi/VW-SAT kit)

To set and change scrolling feature press CAT/FLDR button repeatedly until Mode 6 is selected . Change options by pressing Seek/Track or turning the Tune dial. After setting the desired feature turn off the ignition for at least 50 seconds to engage the new selection.

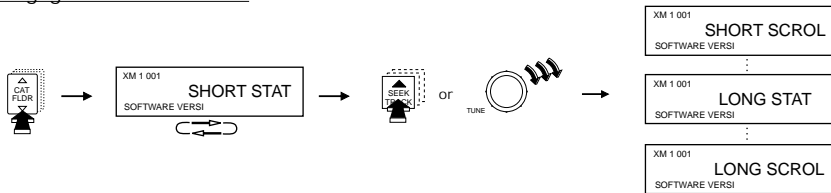

Certain amount of blinking is normal on some radios when the scrolling feature is on.

## Firmware version information - in SAT emulation, Mode 6

Firmware versions are displayed while in Mode 6. This may be needed by a support technician if troubleshooting is necessary. Having this information ready before requesting technical support may expedite the troubleshooting process.



## Auxiliary audio source

### Connections

The interface is equipped with a 1/8" AUX jack connection to connect an auxiliary device, such as an MP3 player, DVD player or other audio source. To access the AUX audio source, select DISC 5, Track 2 or Mode 5, Channel 2.

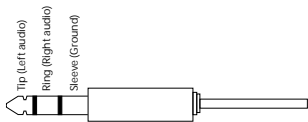
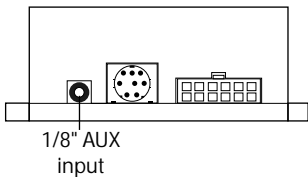

1/8" mini stereo jack, not included

### Making the adjustments

While listening to the auxiliary device, adjust the volume (gain), bass, mid and treble by turning the Tune dial or pressing the Seek button. DISC/Mode 1-4 modes select what adjustment the Tune/Seek buttons perform. See illustration on page 32.

## AUX audio source setting

The auxiliary input has settings for gain, bass, mid and treble in order to optimize sound.

Volume (Gain) should be adjusted if the audio level from the auxiliary device is too low or to high. If you hear distorted audio while playing the auxiliary device, you need to reduce (-) the gain. If you notice that the audio is too quiet then the gain setting should be increased (+). Default settings are "50" ("68" for gain) and values may be adjusted in increments between 01-99. Bass, Mid and Treble should be adjusted to compensate for the acoustic presets of the radio.

Note: If you are using an AUX device that is using the vehicle's power source and not its own battery, you may have to use a GROUND-LOOP isolator to avoid grounding and engine noise.

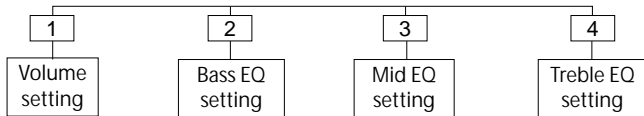

## Troubleshooting

Problem	Solution
Cannot select the interface.	Check DIP switch settings (refer to pp.11, 23). With the ignition OFF disconnect vehicle harness from module for a few seconds and reconnect. Verify that the correct button is used to access the interface (CDC or SAT).
No audio from iPod source.	Reset the iPod. Verify proper connection to interface.
Radio/ steering wheel controls do not operate iPod.	Reset iPod and make sure most recent iPod firmware is installed. Check vehicle user manual on how steering wheel controls work.
Radio/ steering wheel controls do not operate iPod, but audio is still present.	Select DISC/Mode 5 and Track/Channel 1. Switch back to DISC/Mode 1 and try changing Tracks.

## Troubleshooting

Problem	Solution
Interface has erratic recognition or not at all.	Make sure that the ground wire harness is attached to back of radio.
Text is not displaying.	Set iPod switches to OFF for "Locked" mode. Text display is only supported on SAT-capable radios.
iPod does not charge.	Check all connections. Reset iPod and make sure iPod charges while connected to computer or wall charger.
Music is distorted or sound level is too low.	Check and make sure all EQ and BASS boost options are turned off on your iPod. (Refer to AUX settings on p.32)

## Disclaimer and warranty

Important disclaimer, please read!

Unauthorized reproduction or reverse engineering is strictly prohibited! Intellectual property included is distributed under specific license agreement with respective owners and is licensed only, not sold. No warranty, explicit or implied, is stated. Neither Neo Car Audio Inc., nor any of its agents, distributors, dealers or vendors shall be liable for damages.

IN NO EVENT SHALL Neo Car Audio Inc. LIABILITY EXCEED THE PRICE PAID FOR THE PRODUCT FROM DIRECT, INDIRECT, SPECIAL, INCIDENTAL, OR CONSEQUENTIAL DAMAGES RESULTING FROM THE USE OF THE PRODUCT, ITS ACCOMPANYING SOFTWARE OR ITS DOCUMENTATION.

### Warranty and Support

Products carry a one year limited warranty that protects you from defects in material and workmanship of products sold by Neo Car Audio Inc., or its authorized agents, distributors and dealers. The warranty period begins the day a product is purchased by the end user. Products found to be defective during the warranty period will either be repaired or replaced by Neo Car Audio Inc. at no charge unless warranty is void. Unauthorized attempt of repair or alteration of the product in any way immediately voids this warranty. Warranty does not extend to cosmetics or finish. A Neo product specialist must determine that defect is present in the product and issue an RMA. Be sure that all wiring is connected as described in the user manual and all related equipment is functioning properly. Neo Car Audio Inc. disclaims any liability for other incurred damages resulting from product defects. Any expenses in the removal and reinstallation of products are not covered by this warranty.

If experience any problems or need help, please contact your local dealer or call 619-704-0699, or visit our support site at <http://www.neocaraudio.com>



Audi/VW compatible integration for iPod  
[www.neocaraudio.com](http://www.neocaraudio.com)

Audi/VW-iPod 2008-03